

## Chapter 1: Equations and Inequalities

*Solve Linear Equations*

Solve the linear equation.

1)  $5x - (2x - 1) = 2$

A)  $\left\{-\frac{1}{7}\right\}$

B)  $\left\{\frac{1}{3}\right\}$

C)  $\left\{-\frac{1}{3}\right\}$

D)  $\left\{\frac{1}{7}\right\}$

*Solve Equations Involving Absolute Value*

Solve the absolute value equation or indicate that the equation has no solution.

2)  $|3x + 7| + 9 = 18$

A)  $\left\{-\frac{16}{3}, \frac{2}{3}\right\}$

B)  $\left\{-\frac{2}{3}, \frac{16}{3}\right\}$

C)  $\emptyset$

D)  $\left\{-\frac{16}{7}, \frac{2}{7}\right\}$

*Solve Linear Equations Containing Fractions*

Solve the linear equation.

3)  $\frac{x}{16} + \frac{9}{8} = \frac{x+3}{8}$

A)  $\{6\}$

B)  $\{12\}$

C)  $\{3\}$

D)  $\{15\}$

*Solve Quadratic Equations by Factoring*

Solve the equation by factoring.

4)  $6x^2 + 23x + 20 = 0$

A)  $\left\{\frac{5}{2}, \frac{4}{3}\right\}$

B)  $\left\{-\frac{5}{6}, -\frac{1}{5}\right\}$

C)  $\left\{\frac{5}{2}, -\frac{4}{3}\right\}$

D)  $\left\{-\frac{5}{2}, -\frac{4}{3}\right\}$

*Solve Quadratic Equations by the Square Root Property*

Solve the quadratic equation by the square root property.

5)  $(x - 4)^2 = 49$

A)  $\{-7, 7\}$

B)  $\{-11, -3\}$

C)  $\{53\}$

D)  $\{-3, 11\}$

*Solve Quadratic Equations by Completing the Square*

Solve the quadratic equation by completing the square.

6)  $x^2 + 14x + 35 = 0$

A)  $\{-7 - \sqrt{14}, -7 + \sqrt{14}\}$

C)  $\{7 + \sqrt{14}\}$

B)  $\{-14 + \sqrt{35}\}$

D)  $\{7 - \sqrt{35}, 7 + \sqrt{35}\}$

*Solve Quadratic Equations Using the Quadratic Formula*

Solve the quadratic equation using the quadratic formula.

7)  $2x^2 + 10x + 4 = 0$

A)  $\left\{ \frac{-5 - \sqrt{17}}{4}, \frac{-5 + \sqrt{17}}{4} \right\}$   
 C)  $\left\{ \frac{-5 - \sqrt{33}}{2}, \frac{-5 + \sqrt{33}}{2} \right\}$

B)  $\left\{ \frac{-5 - \sqrt{17}}{2}, \frac{-5 + \sqrt{17}}{2} \right\}$   
 D)  $\left\{ \frac{-10 - \sqrt{17}}{2}, \frac{-10 + \sqrt{17}}{2} \right\}$

*Use the Discriminant to Determine the Number and Type of Solutions of Quadratic Equations*

Compute the discriminant. Then determine the number and type of solutions for the given equation.

8)  $5x^2 = 4x - 2$

- A) -56; no real solution  
 C) -24; no real solution

- B) 56; two unequal real solutions  
 D) 0; one real solution

*Determine the Most Efficient Method to Use When Solving a Quadratic Equation*

Solve the quadratic equation by the method of your choice.

9)  $8x^2 - 6 = 47x$

A)  $\left\{ \frac{1}{47}, -\frac{1}{8} \right\}$

B)  $\left\{ -\frac{1}{8}, 8 \right\}$

C)  $\left\{ -\frac{1}{8}, 6 \right\}$

D)  $\{-8, 6\}$

*Use Equations to Solve Problems*

Solve the problem.

10) A local race for charity has taken place since 1993. In 1993, the winning speed was 5 miles per hour. The winning speed increased, on average, by 0.16 miles per hour each year in the period 1993-1998. If this trend continues, in which year is the winning speed predicted to be 6.6 mph?

A) 2002

B) 2005

C) 2004

D) 2003

*Use Interval Notation*

Express the interval in set-builder notation and graph the interval on a number line.

11)  $[-1, 6)$

A)  $\{x \mid -1 \leq x < 6\}$

B)  $\{x \mid -1 < x \leq 6\}$

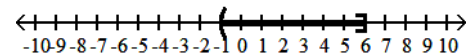
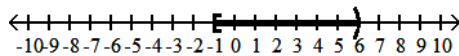

C)  $\{x \mid -1 \leq x \leq 6\}$

D)  $\{x \mid x < 6\}$

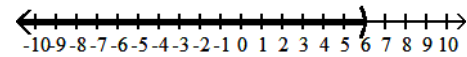
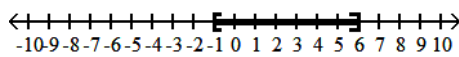

*Find Intersections and Unions of Intervals*

Use graphs to find the set.

12)  $(-\infty, 4) \cup [-7, 14)$

A)  $(-\infty, 14)$

B)  $(-\infty, -7]$

C)  $[-7, 4)$

D)  $(4, 14)$

### Solve Linear Inequalities

Solve the linear inequality. Other than  $\emptyset$ , use interval notation to express the solution set and graph the solution set on a number line.

13)  $8x - 5 > 7x - 7$

A)  $(-2, \infty)$

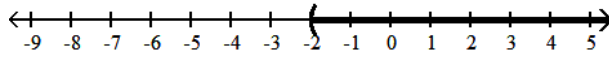

B)  $[-2, \infty)$

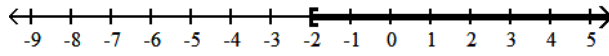

C)  $(-\infty, -2]$

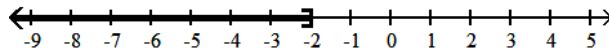

D)  $(-12, \infty)$

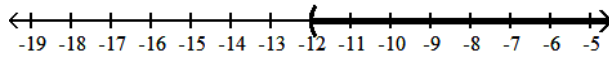

### Solve Compound Inequalities

Solve the compound inequality. Other than  $\emptyset$ , use interval notation to express the solution set and graph the solution set on a number line.

14)  $10 \leq 4x - 2 \leq 18$

A)  $[3, 5]$

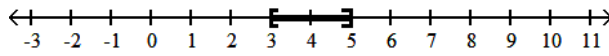

B)  $(-5, -3)$

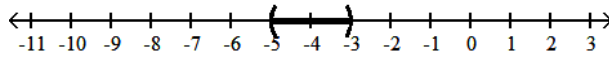

C)  $[-5, -3]$

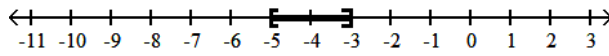

D)  $(3, 5)$

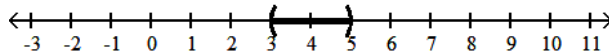

### Solve Absolute Value Inequalities

Solve the absolute value inequality. Other than  $\emptyset$ , use interval notation to express the solution set and graph the solution set on a number line.

15)  $|5x - 9| - 1 < -3$

A)  $\left(-\infty, \frac{7}{5}\right)$

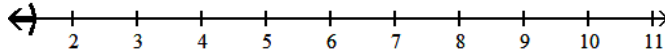

B)  $\left(-\infty, \frac{11}{5}\right)$

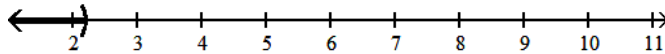

C)  $\left(\frac{7}{5}, \frac{11}{5}\right)$

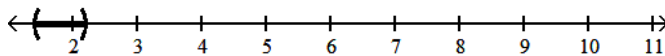

D)  $\emptyset$

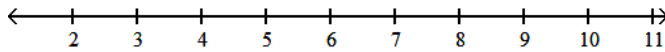

### Add and Subtract Complex Numbers

Add or subtract as indicated and write the result in standard form.

16)  $9i + (-6 - i)$

A)  $6 - 10i$

B)  $6 - 8i$

C)  $-6 + 8i$

D)  $-6 + 10i$

### Multiply Complex Numbers

Find the product and write the result in standard form.

17)  $(4 - 7i)(-5 - 2i)$

A)  $-6 - 43i$

B)  $-34 + 27i$

C)  $-6 + 27i$

D)  $-34 - 43i$

### Divide Complex Numbers

Divide and express the result in standard form.

18)  $\frac{5}{9+i}$

A)  $\frac{45}{82} - \frac{5}{82}i$

B)  $\frac{9}{16} + \frac{1}{16}i$

C)  $\frac{9}{16} - \frac{1}{16}i$

D)  $\frac{45}{82} + \frac{5}{82}i$

### Perform Operations with Square Roots of Negative Numbers

Perform the indicated operations and write the result in standard form.

19)  $3\sqrt{-36} + 4\sqrt{-81}$

A)  $-54i$

B)  $54i$

C)  $54$

D)  $-54$

## Chapter 3: Functions



### Plot Points in the Rectangular Coordinate System

Plot the given point in a rectangular coordinate system.

20)  $(3, 0)$

A)

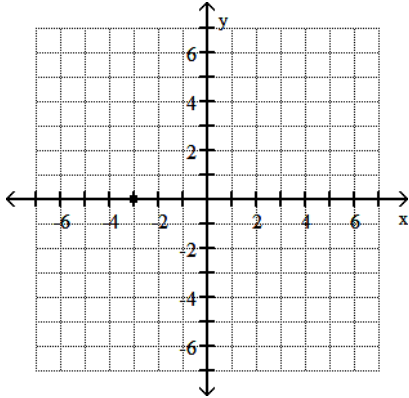

B)

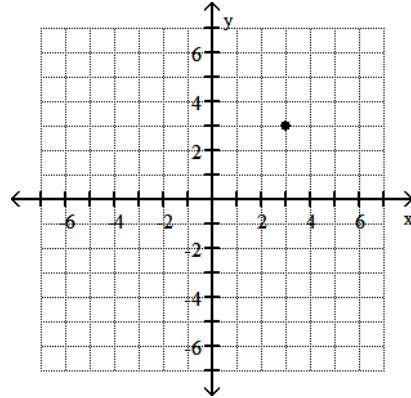

C)

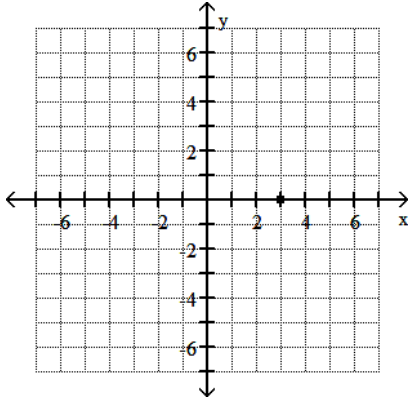

D)

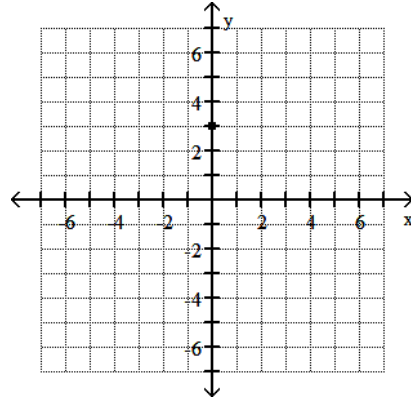

### Find the Domain and Range of a Relation

Give the domain and range of the relation.

21)  $\{(6, 5), (6, 8), (-8, 2), (-5, -4), (-11, 9)\}$

- A) domain =  $\{6, -8, -5, -11\}$ ; range =  $\{8, 2, -4, 9, 5\}$
- B) domain =  $\{6, -2, -8, -5, -11\}$ ; range =  $\{8, 2, -4, 9, 5\}$
- C) domain =  $\{6, 12, -8, -5, -11\}$ ; range =  $\{8, 2, -4, 9, 5\}$
- D) domain =  $\{8, 2, -4, 9, 5\}$ ; range =  $\{6, 6, -8, -5, -11\}$

### Determine Whether a Relation is a Function

Determine whether the relation is a function.

22)  $\{(-4, 8), (-3, 7), (2, -3), (2, 2)\}$

A) Not a function

B) Function

*Determine Whether an Equation Represents a Function*

Determine whether the equation defines y as a function of x.

23)  $x + y^3 = 27$

A) y is a function of x

B) y is not a function of x

*Evaluate a Function*

Evaluate the function at the given value of the independent variable and simplify.

24)  $f(x) = \sqrt{x + 13}$ ;  $f(-4)$

A) -3

B) 1.73

C) 3

D) not a real number

*Use a Graph to Determine Intercepts*

Use the graph to determine the x- and y-intercepts.

25)

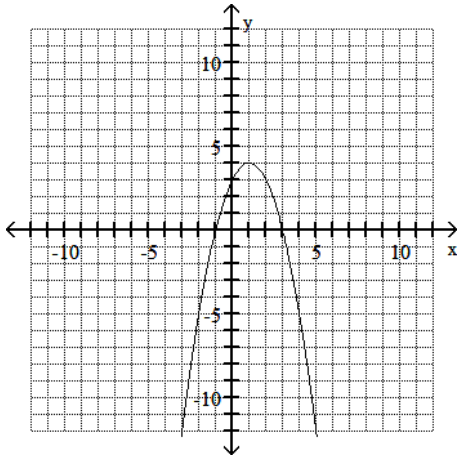

A) x-intercept: 3; y-intercepts: -1, 3

C) x-intercept: -1; y-intercepts: 3, 3

B) x-intercepts: -1, 3; y-intercept: 3

D) x-intercept: 3; y-intercept: 3

*Use the Vertical Line Test to Identify Functions*

Use the vertical line test to determine whether or not the graph is a graph in which y is a function of x.

26)

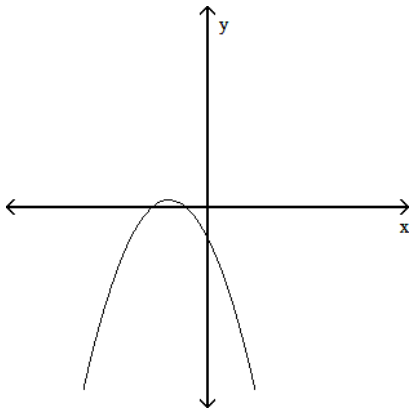

A) function

B) not a function

*Graph Equations in the Rectangular Coordinate System*

Graph the equation.

27)  $y = 2x + 6$

A)

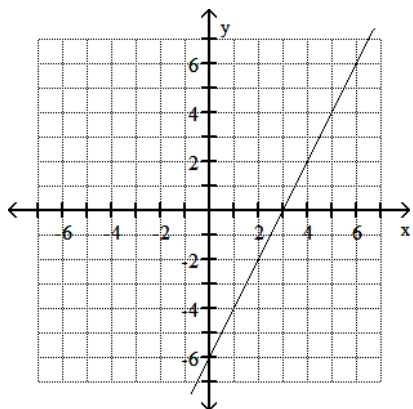

B)

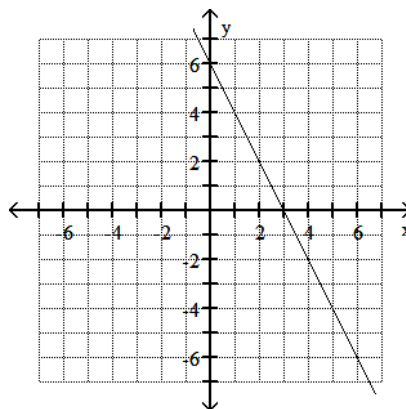

C)

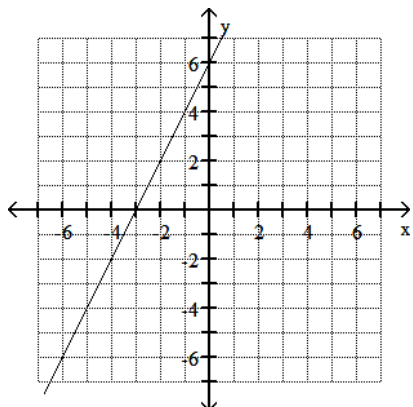

D)

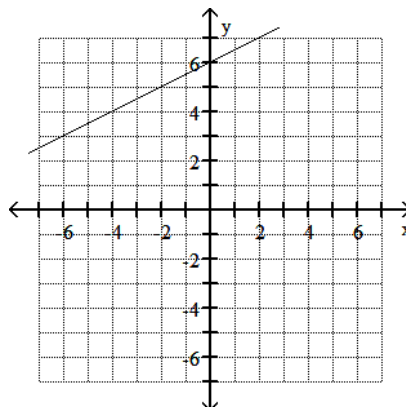

*Obtain Information About a Function from Its Graph*

Use the graph to find the indicated function value.

28)  $y = f(x)$ . Find  $f(-2)$

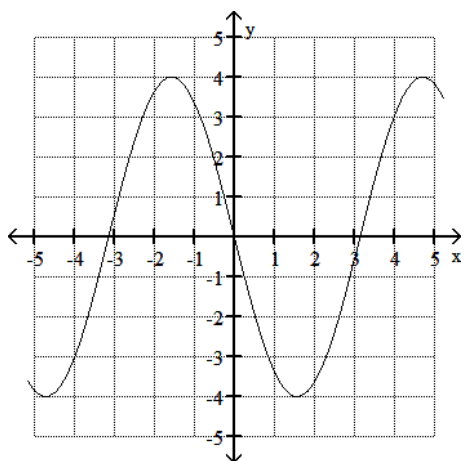

A) 0.5

B) -3.6

C) -0.5

D) 3.6

*Graph Functions by Plotting Points*

Graph the given functions on the same rectangular coordinate system. Describe how the graph of  $g$  is related to the graph of  $f$ .

29)  $f(x) = x$ ,  $g(x) = x + 2$

A)  $g$  shifts the graph of  $f$  vertically down 2 units

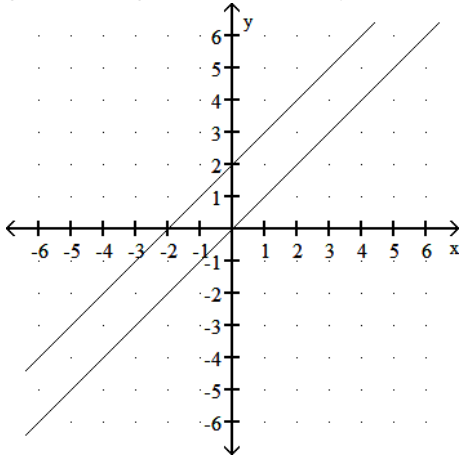

B)  $g$  shifts the graph of  $f$  vertically up 2 units

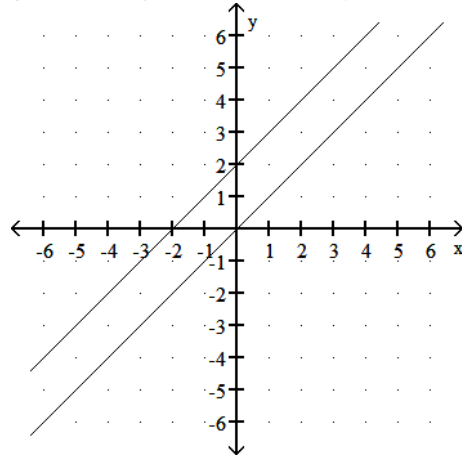

C)  $g$  shifts the graph of  $f$  vertically up 2 units

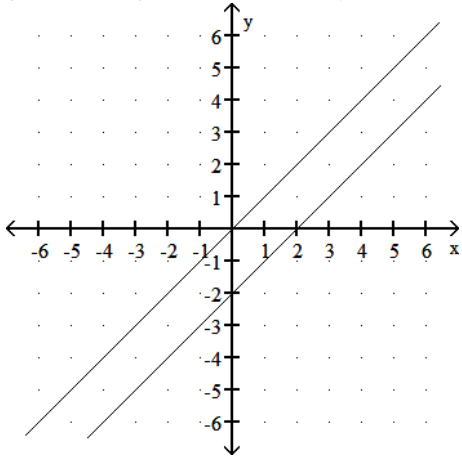

D)  $g$  shifts the graph of  $f$  vertically down 2 units

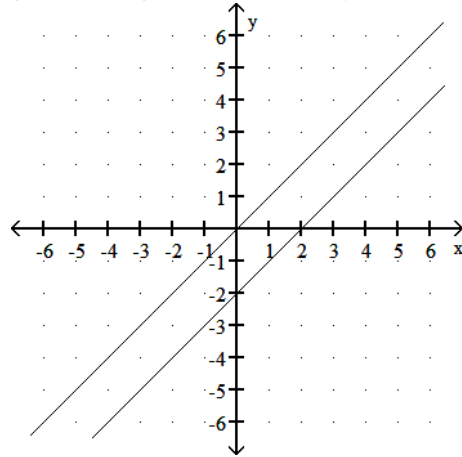

*Identify the Domain and Range of a Function from Its Graph*

Use the graph to determine the function's domain and range.

30)

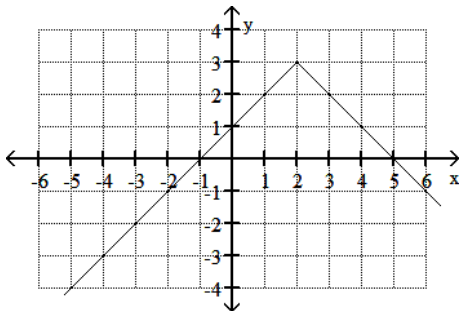

- A) domain:  $(-\infty, 2]$   
range:  $(-\infty, 3]$
- C) domain:  $(-\infty, 2)$   
range:  $(-\infty, 3]$

- B) domain:  $(-\infty, \infty)$   
range:  $(-\infty, \infty)$
- D) domain:  $(-\infty, 2)$  or  $(2, \infty)$   
range:  $(-\infty, 3)$  or  $(3, \infty)$

*Interpret Information Given by Graphs*

Match the story with the correct figure.

31) The height of an animal as a function of time.

A)

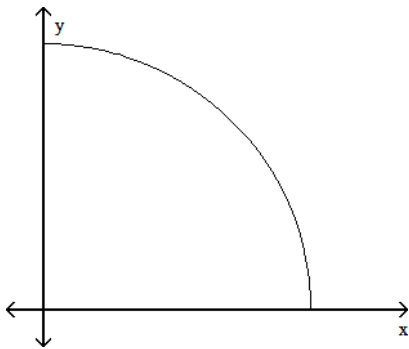

B)

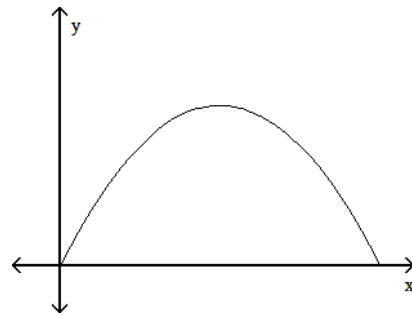

C)

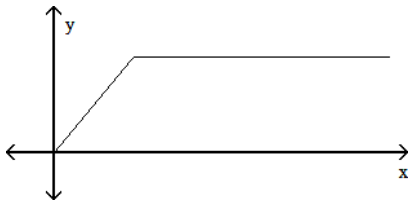

D)

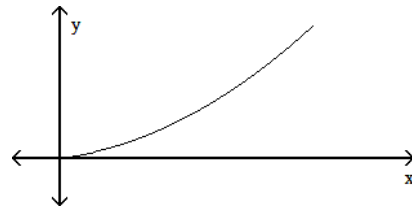

*Identify Intercepts from a Function's Graph*

Identify the intercepts.

32)

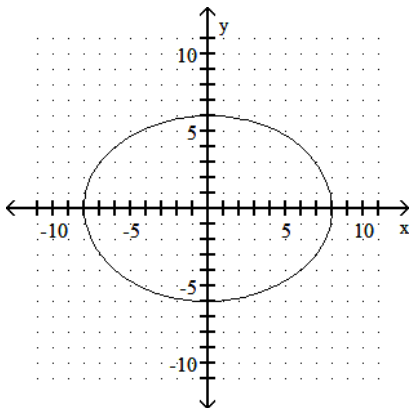

- A) (6, 0), (-6, 0), (0, 8), (0, -8)
- C) (8, 0), (-8, 0)

- B) (8, 0), (-8, 0), (0, 6), (0, -6)
- D) (0, 6), (0, -6)

*Identify Even or Odd Functions and Recognize Their Symmetries*

Determine whether the given function is even, odd, or neither.

33)  $f(x) = x^3 + x^2 - 4$

A) Odd

B) Even

C) Neither

### Understand and Use Piecewise Functions

Evaluate the piecewise function at the given value of the independent variable.

$$34) h(x) = \begin{cases} \frac{x^2 - 3}{x - 7} & \text{if } x \neq 7; h(7) \\ x - 8 & \text{if } x = 7 \end{cases}$$

A) -1

B) 1

C) 15

D) undefined

### Find and Simplify a Function's Difference Quotient

Find and simplify the difference quotient  $\frac{f(x+h) - f(x)}{h}$ ,  $h \neq 0$  for the given function.

$$35) f(x) = x^2 + 9x - 7$$

A)  $\frac{2x^2 + 2x + 2xh + h^2 + h - 14}{h}$

B)  $2x + h - 7$

C)  $2x + h + 9$

D) 1

### Find the Domain of a Function

Find the domain of the function.

$$36) f(x) = \frac{x^2}{x^2 + 6}$$

A)  $(-6, \infty)$

B)  $(-\infty, 0) \cup (0, \infty)$

C)  $(-\infty, -6) \cup (-6, \infty)$

D)  $(-\infty, \infty)$

### Combine Functions Using the Algebra of Functions, Specifying Domains

Given functions  $f$  and  $g$ , perform the indicated operations.

$$37) f(x) = \sqrt{4x + 2}, \quad g(x) = \sqrt{25x - 16}$$

Find  $fg$ .

A)  $(5x - 4)(\sqrt{4x + 2})$

B)  $(4x + 2)(25x - 16)$

C)  $(4x + 2)(5x - 4)$

D)  $(\sqrt{4x + 2})(\sqrt{25x - 16})$

### Form Composite Functions

For the given functions  $f$  and  $g$ , find the indicated composition.

$$38) f(x) = \frac{x - 4}{5}, \quad g(x) = 5x + 4$$

$(g \circ f)(x)$

A)  $x$

B)  $x - \frac{4}{5}$

C)  $x + 8$

D)  $5x + 16$

### Determine Domains for Composite Functions

Find the domain of the composite function  $f \circ g$ .

$$39) f(x) = \sqrt{x}; \quad g(x) = 5x + 25$$

A)  $[-5, \infty)$

B)  $[0, \infty)$

C)  $(-\infty, \infty)$

D)  $(-\infty, -5]$  or  $[0, \infty)$

*Write Functions as Compositions*

Find functions  $f$  and  $g$  so that  $h(x) = (f \circ g)(x)$ .

40)  $h(x) = |2x + 7|$

A)  $f(x) = x, g(x) = 2x + 7$

C)  $f(x) = |-x|, g(x) = 2x - 7$

B)  $f(x) = -|x|, g(x) = 2x + 7$

D)  $f(x) = |x|, g(x) = 2x + 7$

*Verify Inverse Functions*

Determine which two functions are inverses of each other.

41)  $f(x) = \sqrt{x}$        $g(x) = \frac{1}{\sqrt{x}}$        $h(x) = x^2$

A)  $g(x)$  and  $h(x)$

B)  $f(x)$  and  $g(x)$

C)  $f(x)$  and  $h(x)$

D) None

*Find the Inverse of a Function*

Find the inverse of the one-to-one function.

42)  $f(x) = \sqrt[3]{x-6}$

A)  $f^{-1}(x) = x^3 + 36$

B)  $f^{-1}(x) = x + 6$

C)  $f^{-1}(x) = x^3 + 6$

D)  $f^{-1}(x) = \frac{1}{x^3 + 6}$

*Use the Horizontal Line Test to Determine if a Function has an Inverse Function*

Does the graph represent a function that has an inverse function?

43)

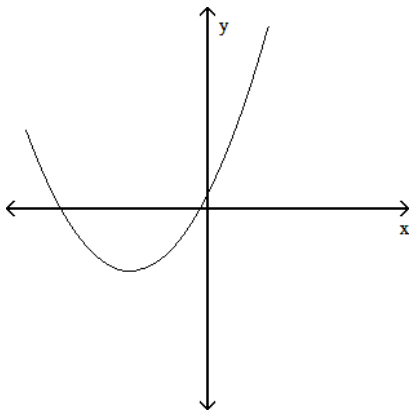

A) Yes

B) No



## Chapter 5: Exponential and Logarithmic Functions

### Evaluate Exponential Functions

Approximate the number using a calculator. Round your answer to three decimal places.

44)  $4^{\sqrt{7}}$

A) 49.000

B) 10.583

C) 8192.000

D) 39.165

### Graph Exponential Functions

Graph the function by making a table of coordinates.

45)  $f(x) = 3^x$

A)

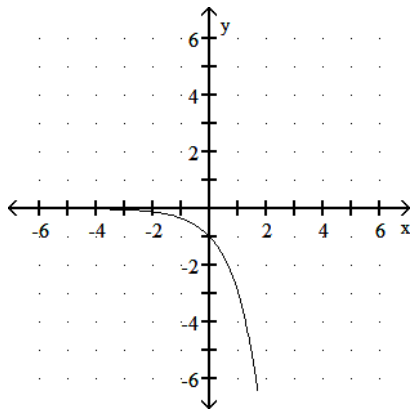

B)

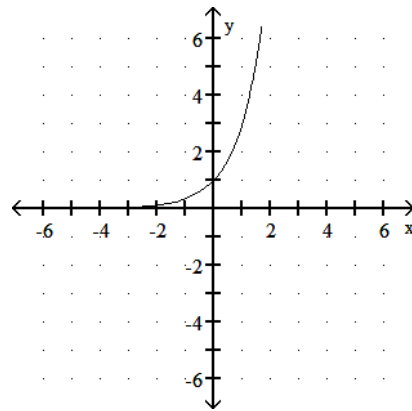

C)

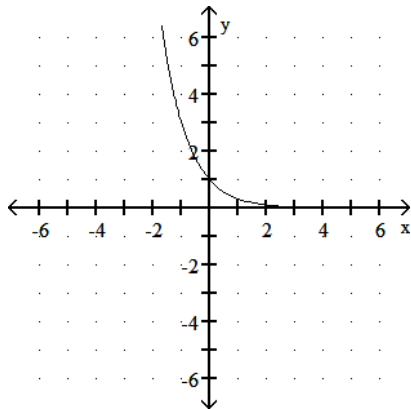

D)

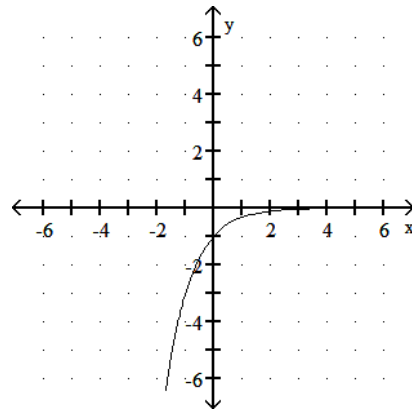

### Evaluate Functions with Base e

Approximate the number using a calculator. Round your answer to three decimal places.

46)  $e^{-2.7}$

A) -7.339

B) 0.067

C) 0.367

D) -0.067

*Change from Logarithmic to Exponential Form*

Write the equation in its equivalent exponential form.

47)  $\log_4 16 = 2$

A)  $16^2 = 4$

B)  $4^{16} = 2$

C)  $4^2 = 16$

D)  $2^4 = 16$

*Change From Exponential to Logarithmic Form*

Write the equation in its equivalent logarithmic form.

48)  $2^3 = x$

A)  $\log_x 2 = 3$

B)  $\log_2 3 = x$

C)  $\log_2 x = 3$

D)  $\log_3 x = 2$

*Evaluate Logarithms*

Evaluate the expression without using a calculator.

49)  $\log_2 \frac{1}{4}$

A) -2

B)  $\frac{1}{2}$

C) 4

D) 2

*Graph Logarithmic Functions*

The graph of a logarithmic function is given. Select the function for the graph from the options.

50)

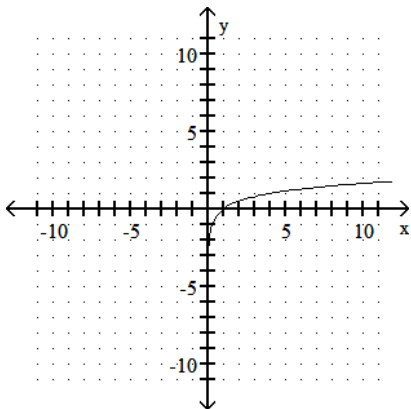

A)  $f(x) = \log_4 (x - 1)$

B)  $f(x) = \log_4 x - 1$

C)  $f(x) = \log_4 (x + 1)$

D)  $f(x) = \log_4 x$

*Use Basic Logarithmic Properties*

Evaluate the expression without using a calculator.

51)  $\log_7 7^{18}$

A) 25

B) 7

C) 18

D)  $\log_7 18$

*Find the Domain of a Logarithmic Function*

Find the domain of the logarithmic function.

52)  $f(x) = \log \left( \frac{x+7}{x-8} \right)$

A)  $(-\infty, -7) \cup (8, \infty)$

B)  $(-\infty, -7)$

C)  $(8, \infty)$

D)  $(-7, 8)$

### Use Common Logarithms

Evaluate or simplify the expression without using a calculator.

53)  $3 \log 105.4$

A) 5.0592

B) 16.2

C) 162

D) 1.62

### Use the Product Rule

Use properties of logarithms to expand the logarithmic expression as much as possible. Where possible, evaluate logarithmic expressions without using a calculator.

54)  $\log_2 (8x)$

A)  $3x$

B)  $3 \log_2 x$

C)  $6 + \log_2 x$

D)  $3 + \log_2 x$

### Use Natural Logarithms

Evaluate or simplify the expression without using a calculator.

55)  $\ln \sqrt[4]{e}$

A)  $\frac{1}{4}$

B)  $4e$

C)  $\frac{e}{4}$

D) 4

### Use the Quotient Rule

### Use the Power Rule

Use properties of logarithms to expand the logarithmic expression as much as possible. Where possible, evaluate logarithmic expressions without using a calculator.

56)  $\log \left( \frac{x}{100} \right)$

A)  $100x$

B)  $\log x - 2$

C)  $-20x$

D)  $\log x + 2$

57)  $\log_7 \sqrt[4]{y}$

A)  $\frac{1}{4} \log_7 y$

B)  $\frac{1}{4} \log_7 \sqrt[4]{y}$

C)  $\frac{1}{7} \log_4 y$

D)  $4 \log_7 y$

### Condense Logarithmic Expressions

Use properties of logarithms to condense the logarithmic expression. Write the expression as a single logarithm whose coefficient is 1. Where possible, evaluate logarithmic expressions.

58)  $\log_4 (x - 8) - \log_4 (x - 4)$

A)  $\log_4 -4$

B)  $\log_4 (x^2 - 12x + 32)$

C)  $\log_4 \left( \frac{x - 8}{x - 4} \right)$

D)  $\log_4 \left( \frac{x - 8}{x + 4} \right)$

### Use Like Bases to Solve Exponential Equations

Solve the equation by expressing each side as a power of the same base and then equating exponents.

59)  $4(1 + 2x) = 64$

A) {16}

B) {1}

C) {-1}

D) {4}

### Expand Logarithmic Expressions

Use properties of logarithms to expand the logarithmic expression as much as possible. Where possible, evaluate logarithmic expressions without using a calculator.

60)  $\log_b (yz^4)$

- A)  $4 \log_b y + 4 \log_b z$       B)  $\log_b y + \log_b 4z$       C)  $4 \log_b yz$       D)  $\log_b y + 4 \log_b z$

### Use Logarithms to Solve Exponential Equations

Solve the exponential equation. Express the solution set in terms of natural logarithms.

61)  $4x + 4 = 52x + 5$

- A)  $\left\{ \ln \left[ \frac{55}{44} - \frac{4}{52} \right] \right\}$       B)  $\left\{ \frac{5 \ln 5 - 4 \ln 4}{\ln 4 - 2 \ln 5} \right\}$       C)  $\{\ln 5 - \ln 4\}$       D)  $\{7 \ln 5 - 5 \ln 4\}$

### Use the Definition of a Logarithm to Solve Logarithmic Equations

### Use the Logarithms rules to Solve Logarithmic Equations

Solve the logarithmic equation. Be sure to reject any value that is not in the domain of the original logarithmic expressions. Give the exact answer.

62)  $\log_3 (x - 1) = -1$

- A)  $\{-2\}$       B)  $\left\{ \frac{4}{3} \right\}$       C)  $\{4\}$       D)  $\left\{ -\frac{2}{3} \right\}$

63)  $\log_6 (5x - 5) = \log_6 (3x + 7)$

- A)  $\{2\}$       B)  $\{1\}$       C)  $\emptyset$       D)  $\{6\}$



## Chapter 6: Trigonometric Functions

### Recognize and Use the Vocabulary of Angles

The given angle is in standard position. Determine the quadrant in which the angle lies.

64)  $-226^\circ$

- A) Quadrant III      B) Quadrant IV      C) Quadrant I      D) Quadrant II

### Use Degree Measure

Classify the angle as acute, right, obtuse, or straight.

65)  $118.964^\circ$

- A) right      B) straight      C) obtuse      D) acute

### Use Radian Measure

Find the radian measure of the central angle of a circle of radius  $r$  that intercepts an arc of length  $s$ .

66)  $r = \frac{1}{5}$  feet,  $s = 4$  feet

- A)  $\frac{4}{5}^\circ$                       B)  $20^\circ$                       C) 20 radians                      D)  $\frac{4}{5}$  radians

### Convert Between Degrees and Radians

Convert the angle in degrees to radians. Express answer as a multiple of  $\pi$ .

67)  $144^\circ$

- A)  $\frac{4\pi}{5}$  radians                      B)  $\frac{3\pi}{4}$  radians                      C)  $\frac{5\pi}{6}$  radians                      D)  $\frac{3}{5}\pi$  radians

### Recognize the Domain and Range of Sine and Cosine Functions

Solve the problem.

68) What is the range of the cosine function?

- A) all real numbers  
B) all real numbers from -1 to 1, inclusive  
C) all real numbers greater than or equal to 1 or less than or equal to -1  
D) all real numbers greater than or equal to 0

### Find Exact Values of the Trigonometric Functions at $\pi/4$

Find the exact value of the trigonometric function. Do not use a calculator.

69)  $\sec \frac{\pi}{4}$

- A)  $\frac{\sqrt{2}}{2}$                       B)  $\sqrt{2}$                       C)  $\frac{2\sqrt{3}}{3}$                       D)  $\sqrt{3}$

### Use a Unit Circle to Define Trigonometric Functions of Real Numbers

The point  $P(x, y)$  on the unit circle that corresponds to a real number  $t$  is given. Find the value of the indicated trigonometric function at  $t$ .

70)  $\left(\frac{4}{7}, \frac{\sqrt{33}}{7}\right)$  Find  $\sin t$ .

- A)  $\frac{\sqrt{33}}{7}$                       B)  $\frac{4}{7}$                       C)  $\frac{4\sqrt{33}}{33}$                       D)  $\frac{\sqrt{33}}{4}$

### Recognize and Use Fundamental Identities

$\sin t$  and  $\cos t$  are given. Use identities to find the indicated value. Where necessary, rationalize denominators.

71)  $\sin t = -\frac{3}{7}$ ,  $\cos t = \frac{2\sqrt{10}}{7}$ . Find  $\tan t$ .

- A)  $\frac{-3\sqrt{10}}{20}$                       B)  $\frac{-3\sqrt{10}}{3}$                       C)  $\frac{7\sqrt{10}}{20}$                       D)  $-\frac{7}{3}$

*Draw Angles in Standard Position*

Draw the angle in standard position.

72)  $\frac{2\pi}{3}$

A)

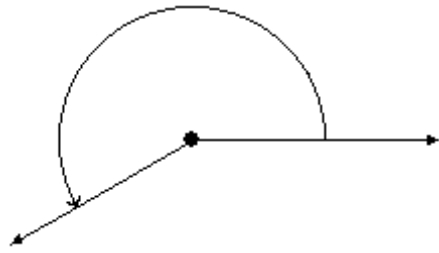

C)

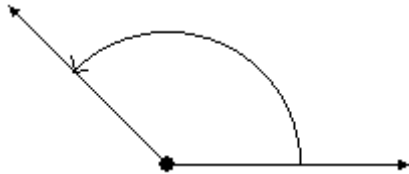

B)

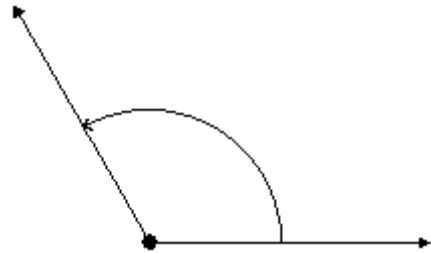

D)

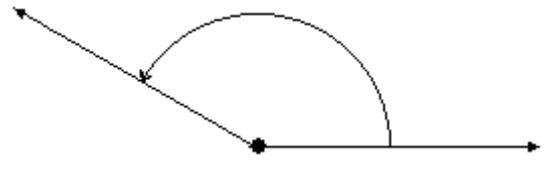

*Use Right Triangles to Evaluate Trigonometric Functions*

Use the Pythagorean Theorem to find the length of the missing side. Then find the indicated trigonometric function of the given angle. Give an exact answer with a rational denominator.

73) Find  $\csc \theta$ .

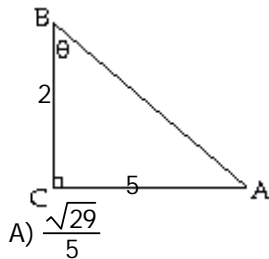

A)  $\frac{\sqrt{29}}{5}$

B)  $\frac{2\sqrt{29}}{29}$

C)  $\frac{5\sqrt{29}}{29}$

D)  $\frac{\sqrt{29}}{2}$

*Use the Signs of the Trigonometric Functions*

Let  $\theta$  be an angle in standard position. Name the quadrant in which the angle  $\theta$  lies.

74)  $\csc \theta > 0, \sec \theta > 0$

A) quadrant I

B) quadrant III

C) quadrant II

D) quadrant IV

*Use the Definitions of Trigonometric Functions of Any Angle*

A point on the terminal side of angle  $\theta$  is given. Find the exact value of the indicated trigonometric function of  $\theta$ .

75) (21, 28) Find  $\sin \theta$ .

A)  $\frac{3}{5}$

B)  $\frac{3}{4}$

C)  $\frac{4}{3}$

D)  $\frac{4}{5}$

*Find Reference Angles*

Find the reference angle for the given angle.

76)  $-64^\circ$

A)  $26^\circ$

B)  $154^\circ$

C)  $64^\circ$

D)  $116^\circ$

*Find Function Values for  $30^\circ(\pi/6)$ ,  $45^\circ(\pi/4)$ , and  $60^\circ(\pi/3)$*

Use the given triangles to evaluate the expression. Rationalize all denominators.

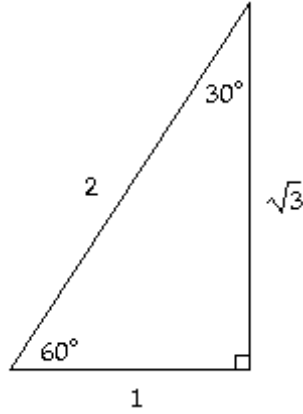
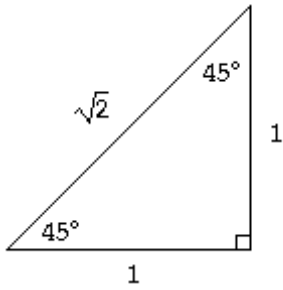

77)  $\sin 60^\circ$

A)  $\frac{\sqrt{3}}{2}$

B)  $\frac{\sqrt{2}}{2}$

C)  $\frac{\sqrt{3}}{3}$

D)  $\frac{1}{2}$

*Use Reference Angles to Evaluate Trigonometric Functions*

Use reference angles to find the exact value of the expression. Do not use a calculator.

78)  $\sin \frac{4\pi}{3}$

A)  $-1$

B)  $\frac{\sqrt{3}}{2}$

C)  $-\frac{\sqrt{3}}{2}$

D)  $-\frac{1}{2}$

*Understand and Use the Inverse Cosine Function*

Find the exact value of the expression.

79)  $\sin^{-1} \frac{\sqrt{3}}{2}$

A)  $\frac{\pi}{4}$

B)  $\frac{2\pi}{3}$

C)  $\frac{3\pi}{4}$

D)  $\frac{\pi}{3}$

*Find Exact Values of Composite Functions with Inverse Trigonometric Functions*

Find the exact value of the expression, if possible. Do not use a calculator.

80)  $\sin^{-1} \left[ \sin \left( \frac{4\pi}{7} \right) \right]$

A)  $\frac{3\pi}{7}$

B)  $\frac{7}{3\pi}$

C)  $\frac{7}{4\pi}$

D)  $\frac{4\pi}{7}$

*Understand and Use the Inverse Cosine Function*

*Understand and Use the Inverse Tan Function*

Find the exact value of the expression.

81)  $\cos^{-1} \frac{\sqrt{2}}{2}$

A)  $\frac{\pi}{6}$

B)  $\frac{\pi}{4}$

C)  $\frac{7\pi}{4}$

D)  $\frac{11\pi}{6}$

82)  $\tan^{-1} \frac{\sqrt{3}}{3}$

A)  $\frac{5\pi}{6}$

B)  $\frac{\pi}{3}$

C)  $\frac{5\pi}{4}$

D)  $\frac{\pi}{6}$



## Chapter 9: Additional Topics in Analytic Geometry

### Graph Ellipses Centered at the Origin

Graph the ellipse and locate the foci.

83)  $\frac{x^2}{64} + \frac{y^2}{4} = 1$

A) foci at  $(\sqrt{77}, 0)$  and  $(-\sqrt{77}, 0)$

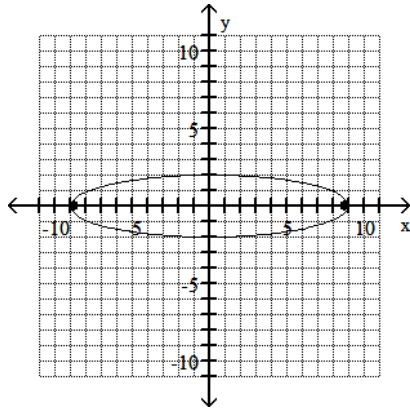

B) foci at  $(0, 2\sqrt{15})$  and  $(0, -2\sqrt{15})$

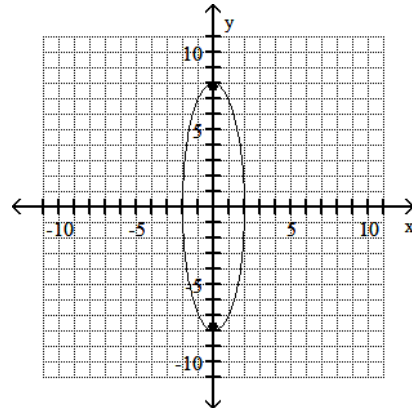

C) foci at  $(2\sqrt{15}, 0)$  and  $(-2\sqrt{15}, 0)$

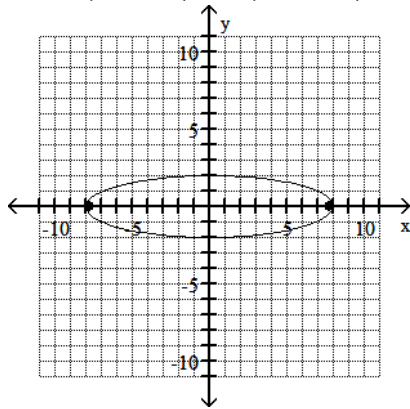

D) foci at  $(0, \sqrt{77})$  and  $(0, -\sqrt{77})$

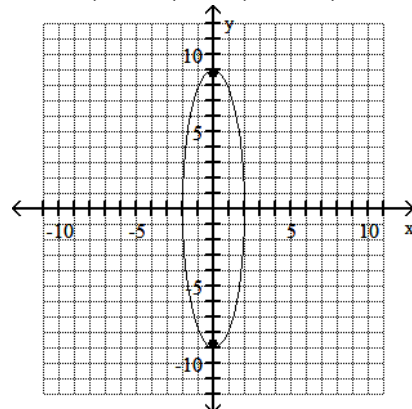

### Locate a Hyperbola's Vertices and Foci

Find the vertices and locate the foci for the hyperbola whose equation is given.

84)  $\frac{x^2}{144} - \frac{y^2}{49} = 1$

A) vertices:  $(-7, 0), (7, 0)$   
foci:  $(-\sqrt{193}, 0), (\sqrt{193}, 0)$

B) vertices:  $(-12, 0), (12, 0)$   
foci:  $(-\sqrt{193}, 0), (\sqrt{193}, 0)$

C) vertices:  $(-12, 0), (12, 0)$   
foci:  $(-7, 0), (7, 0)$

D) vertices:  $(0, -12), (0, 12)$   
foci:  $(-\sqrt{193}, 0), (\sqrt{193}, 0)$

*Write Equations of Ellipses in Standard Form*

Find the standard form of the equation of the ellipse and give the location of its foci.

85)

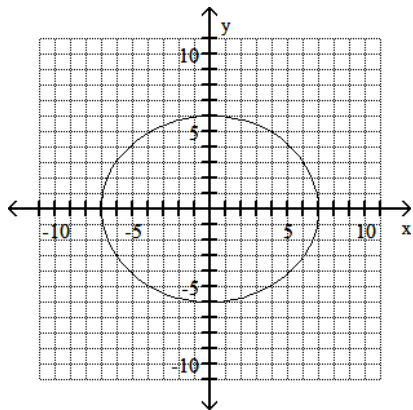

A)  $\frac{x^2}{49} + \frac{y^2}{36} = 1$

foci at  $(-7, 0)$  and  $(7, 0)$

C)  $\frac{x^2}{49} + \frac{y^2}{36} = 1$

foci at  $(-\sqrt{13}, 0)$  and  $(\sqrt{13}, 0)$

B)  $\frac{x^2}{49} - \frac{y^2}{36} = 1$

foci at  $(-\sqrt{13}, 0)$  and  $(\sqrt{13}, 0)$

D)  $\frac{x^2}{36} + \frac{y^2}{49} = 1$

foci at  $(-\sqrt{13}, 0)$  and  $(\sqrt{13}, 0)$

*Write Equations of Hyperbolas in Standard Form*

Find the standard form of the equation of the hyperbola satisfying the given conditions.

86) Endpoints of transverse axis:  $(0, -10)$ ,  $(0, 10)$ ; asymptote:  $y = \frac{5}{8}x$

A)  $\frac{y^2}{100} - \frac{x^2}{256} = 1$

B)  $\frac{y^2}{64} - \frac{x^2}{25} = 1$

C)  $\frac{y^2}{100} - \frac{x^2}{64} = 1$

D)  $\frac{y^2}{256} - \frac{x^2}{100} = 1$

*Graph Parabolas with Vertices at the Origin*

Find the focus and directrix of the parabola with the given equation.

87)  $y^2 = -24x$

A) focus:  $(6, 0)$   
directrix:  $x = -6$

B) focus:  $(-6, 0)$   
directrix:  $x = 6$

C) focus:  $(-6, 0)$   
directrix:  $y = 6$

D) focus:  $(0, -6)$   
directrix:  $y = 6$

*Write Equations of Parabolas in Standard Form*

Find the standard form of the equation of the parabola using the information given.

88) Vertex:  $(6, -4)$ ; Focus:  $(3, -4)$

A)  $(y + 4)^2 = -12(x - 6)$

B)  $(y + 4)^2 = 12(x - 6)$

C)  $(x + 6)^2 = 4(y - 4)$

D)  $(x + 6)^2 = -4(y - 4)$

*Graph Hyperbolas Centered at the Origin*

Use vertices and asymptotes to graph the hyperbola. Find the equations of the asymptotes.

89)  $\frac{x^2}{9} - \frac{y^2}{36} = 1$

A) Asymptotes:  $y = \pm \frac{1}{2}x$

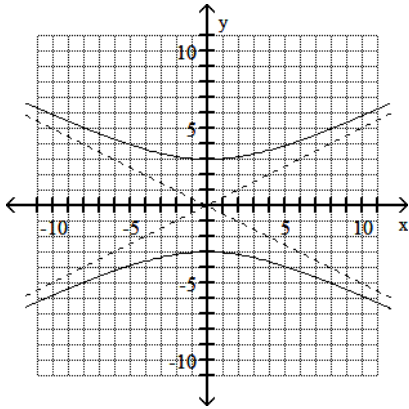

B) Asymptotes:  $y = \pm 2x$

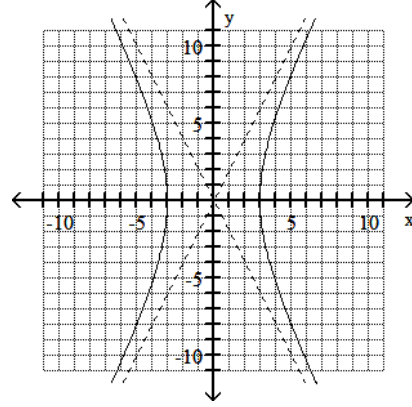

C) Asymptotes:  $y = \pm 2x$

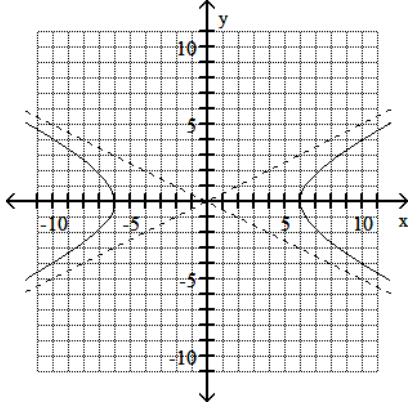

D) Asymptotes:  $y = \pm \frac{1}{2}x$

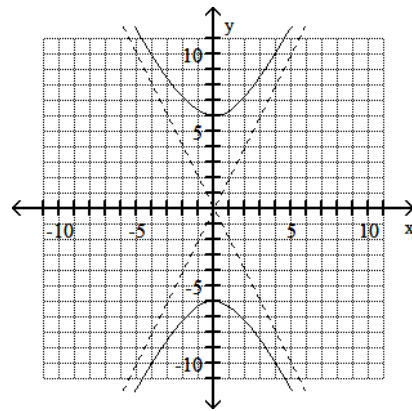

**Chapter 10: Systems of Equations and Inequalities; Matrices**

*Decide Whether an Ordered Pair is a Solution of a Linear System*

Determine whether the given ordered pair is a solution of the system.

90) (1, -3)

$x + y = -4$

$x - y = 2$

A) solution

B) not a solution

### Solve Linear Systems by Substitution

Solve the system of equations by the substitution method.

91)

$$4x - 2y = -70$$

$$x = -3y$$

A)  $\{(-14, 5)\}$

B)  $\{(-15, 5)\}$

C)  $\{(5, -15)\}$

D)  $\{(-15, -5)\}$

### Solve Linear Systems by Addition

Solve the system by the addition method.

92)  $2x + 6y = -10$

$$-2x - 12y = 22$$

A)  $\{(1, -2)\}$

B)  $\{(-1, -2)\}$

C)  $\{(-1, 2)\}$

D)  $\emptyset$

### Identify Systems That Do Not Have Exactly One Ordered-Pair Solution

Solve the system by the method of your choice. Identify systems with no solution and systems with infinitely many solutions, using set notation to express their solution sets.

93)  $x + y = -6$

$$x + y = -7$$

A)  $\{(0, -13)\}$

B)  $\{(-6, -7)\}$

C)  $\{(x, y) \mid x + y = -6\}$

D)  $\emptyset$

### Verify the Solution of a System of Linear Equations in Three Variables

Determine if the given ordered triple is a solution of the system.

94)  $(-4, -3, 1)$

$$x + y + z = -6$$

$$x - y + 5z = -16$$

$$2x + y + z = -5$$

A) solution

B) not a solution

### Solve Systems of Linear Equations in Three Variables

Solve the system of equations.

95)  $x + y + z = 3$

$$x - y + 2z = 9$$

$$5x + y + z = 15$$

A)  $\{(-2, 3, 2)\}$

B)  $\{(3, -2, 2)\}$

C)  $\{(2, 3, -2)\}$

D)  $\{(2, -2, 3)\}$

### Perform Matrix Row Operations

Perform the matrix row operation (or operations) and write the new matrix.

96)

$$\left[ \begin{array}{ccc|c} 4 & -5 & 1 & 1 \\ -4 & 0 & 5 & -2 \\ -1 & 3 & -3 & -1 \end{array} \right] -4R_1 + R_2$$

A)

$$\left[ \begin{array}{ccc|c} 20 & -5 & -19 & 9 \\ -4 & 0 & 5 & -2 \\ -1 & 3 & -3 & -1 \end{array} \right]$$

B)

$$\left[ \begin{array}{ccc|c} 4 & -5 & 1 & 1 \\ 12 & -20 & 9 & 2 \\ -1 & 3 & -3 & -1 \end{array} \right]$$

C)

$$\left[ \begin{array}{ccc|c} -20 & 20 & 1 & -6 \\ -4 & 0 & 5 & -2 \\ -1 & 3 & -3 & -1 \end{array} \right]$$

D)

$$\left[ \begin{array}{ccc|c} 4 & -5 & 1 & 1 \\ -20 & 20 & 1 & -6 \\ -1 & 3 & -3 & -1 \end{array} \right]$$

### Use Matrix Notation

Give the order of the matrix, and identify the given element of the matrix.

97)

$$\begin{bmatrix} 10 & -11 & 8 & -4 \\ 14 & 13 & -8 & 11 \end{bmatrix}; a_{12}$$

A)  $4 \times 2; 14$

B)  $2 \times 4; 14$

C)  $2 \times 4; -11$

D)  $4 \times 2; -11$

### Understand What is Meant by Equal Matrices

Find values for the variables so that the matrices are equal.

98)

$$\begin{bmatrix} x+3 & y+4 \\ 7 & 1 \end{bmatrix} = \begin{bmatrix} 7 & 8 \\ 7 & z \end{bmatrix}$$

A)  $x = 4; y = 1; z = 7$

B)  $x = 4; y = 4; z = 1$

C)  $x = -4; y = -4; z = -1$

D)  $x = 7; y = 8; z = 1$

### Perform Scalar Multiplication

Solve the problem.

99)

Let  $A = \begin{bmatrix} -3 & 6 \\ 0 & 2 \end{bmatrix}$ . Find  $2A$ .

A)  $\begin{bmatrix} -6 & 12 \\ 0 & 2 \end{bmatrix}$

B)  $\begin{bmatrix} -6 & 12 \\ 0 & 4 \end{bmatrix}$

C)  $\begin{bmatrix} -6 & 6 \\ 0 & 2 \end{bmatrix}$

D)  $\begin{bmatrix} -1 & 8 \\ 2 & 4 \end{bmatrix}$

### Multiply Matrices

Find the product  $AB$ , if possible.

100)

$A = \begin{bmatrix} -1 & 3 \\ 4 & 2 \end{bmatrix}$ ,  $B = \begin{bmatrix} -2 & 0 \\ -1 & 3 \end{bmatrix}$

A)  $\begin{bmatrix} 2 & -6 \\ -3 & 3 \end{bmatrix}$

B)  $\begin{bmatrix} 9 & -1 \\ 6 & -10 \end{bmatrix}$

C)  $\begin{bmatrix} -1 & 9 \\ -10 & 6 \end{bmatrix}$

D)  $\begin{bmatrix} 2 & 0 \\ -4 & 6 \end{bmatrix}$

### Evaluate a Second-Order Determinant

Evaluate the determinant.

101)

$$\begin{vmatrix} \frac{1}{12} & -\frac{1}{9} \\ 9 & 12 \end{vmatrix}$$

A) 2

B) 0

C) -2

D)  $\frac{25}{12}$

Prepared by: D. Ayman Hilmi Khashan  
Coordinator of Math 140